

WL56 LOADER





The quality and support you expect. At a price you won't.

The WL56 Loader gives you the functionality you need for general construction work with the quality and support you can depend on to keep moving. It's John Deere designed and built with simple, proven components for great reliability. All at a price that will be a pleasant surprise. See your John Deere dealer for details.





The automatic, electronic PowerShift transmission features four forward and three reverse speeds. Ground-level sight gauge and oil fill provide easy maintenance.

Dependable hydraulic flow is provided by dual gear-type pumps. O-ring face-seal couplers virtually eliminate leaks.

1. The WL56 is simple and inexpensive to maintain. Service doors provide wide-open, convenient access to service points and filters to help speed daily checks and periodic maintenance.
2. Hard-working, reliable John Deere PowerTech engines are coupled with an efficient cooling system to deliver dependable power that won't let you down, even in the most extreme conditions.

3. John Deere wet-disc brake axles are designed with superior engineering, innovative manufacturing processes, and high-strength, lightweight materials to ensure maximum uptime, longer life, and lower operating cost.

4. Spacious, comfortable Rollover Protective Structure (ROPS) cab provides everything an operator needs to stay productive during a long shift, including an adjustable high-back seat and plenty of storage space, complete with a beverage holder. Gauges on the front console are clearly visible, intuitive, and easy to read. Automotive-style directional louvers provide effective airflow to keep the glass clear and the cab comfortable.

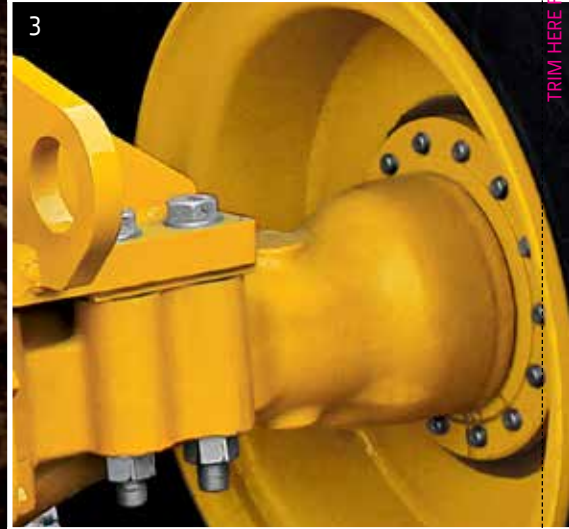
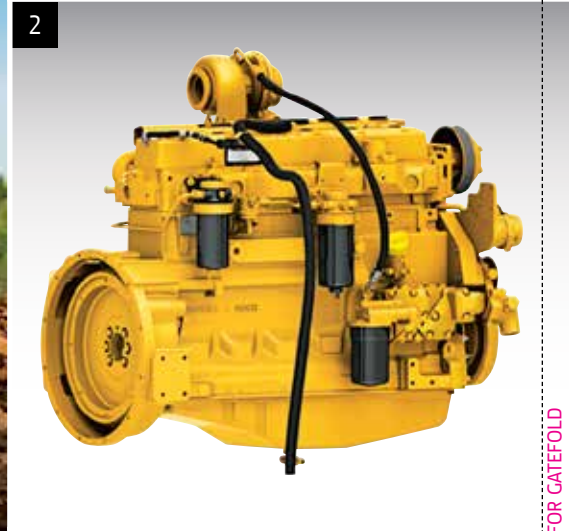

Engine		WL56 Z-BAR	
Manufacturer and Model	John Deere PowerTech 6068H		
Off-Road Emission Standard	EU Stage II		
Cylinders	6		
Displacement	6.8 L		
Gross Rated Power at 2,200 rpm (ISO 9249)	160 kW		
Net Peak Torque at 1,500 rpm (ISO 9249)	917 Nm		
Aspiration	Turbocharged, charge air cooled		
Transmission, Standard			
Type	Countershaft-type PowerShift, 4-speed standard		
Maximum Travel Speeds (with 23.5-25 tires)	<i>Forward</i>	<i>Reverse</i>	
Gear 1	6.45 km/h	6.45 km/h	
Gear 2	11.8 km/h	11.8 km/h	
Gear 3	25.25 km/h	25.25 km/h	
Gear 4	40.0 km/h	—	
Torque Converter	Single stage, single phase		
Shift Modes	Electrohydraulic		
Axles, Standard			
Manufacturer	John Deere		
Type	Wet-disc brake, heavy-duty axles with inboard-planetary final drive		
Rear Axle Oscillation, Stop to Stop	26 deg.		
Differentials	Conventional front and rear axle		
Steering/Brakes			
Steering (conforms to ISO 5010)			
Type	Power, fully hydraulic		
Steering Relief Pressure	17 000 kPa		
Articulation Angle	80-deg. arc (40 deg. each direction)		
Brakes (conform to ISO 3450)			
Service	Hydraulic actuated, wet disc		
Parking	Automatic spring applied, hydraulically released, transmission mounted		
Hydraulic System			
Pump (loader and steering)	Gear pump, fixed displacement		
Maximum Rated Flow at 2,200 rpm	330 L/m		
System Relief Pressure	21 000 kPa		
Hydraulic Cycle Times	<i>Standard Z-Bar</i>		
Raise	5.49 sec.		
Dump	1.8 sec.		
Lower (float down)	3.9 sec.		
Total (float down)	11.19 sec.		
Loader Controls	2-function valve; 2-lever control; hydraulic function enable/disable		
Electrical System			
Voltage	24 volt		
Number of Batteries (12 volt)	2		
Battery Capacity	925 CCA (each)		
Alternator	80 amp		
Tires/Wheels			
Standard size, 23.5-25TL, 16PR with 3-piece rims			
Serviceability			
Refill Capacities			
Axle Oil (front and rear, each)	27.2 L		
Cooling System	28 L		
Engine Oil with Vertical Spin-On Filter	19 L		
Fuel Tank	240 L		
Hydraulic Reservoir and Filters	115 L		
PowerShift Transmission Fluid with Spin-On Filter	34 L		
Operating Weight			
Standard Z-Bar			
With 3.1-m ³ Pin-On General-Purpose Bucket with Bolt-On Cutting Edge	16 783 kg		

Specifications are subject to change without further notice in accordance with our continuous product improvements.

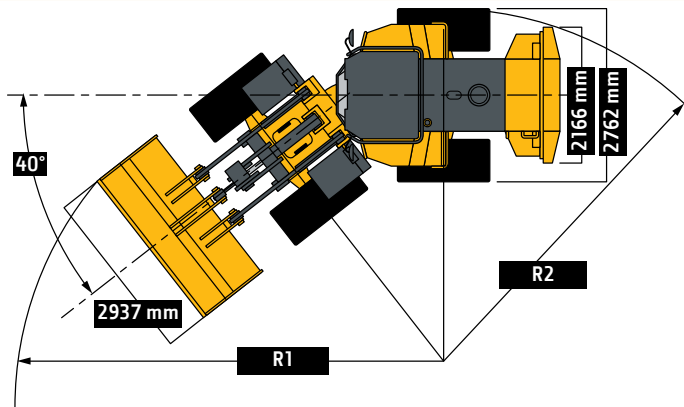
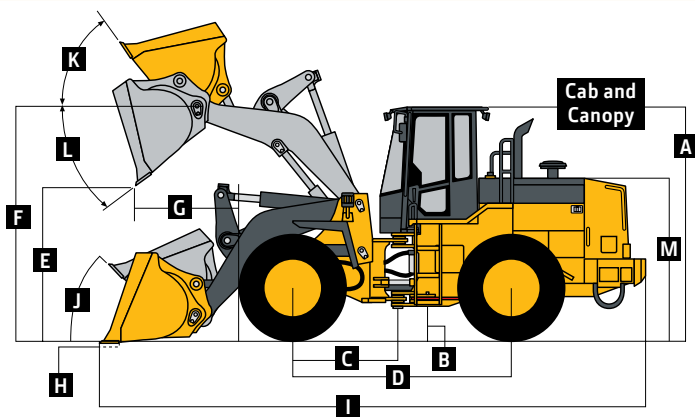

Boom Type

Standard

High Lift

Bucket Type	General Purpose w/ Bolt-On Cutting Edges	General Purpose w/ Teeth and Segments	General Purpose w/ Bolt-On Teeth and Skid Shoes	General Purpose w/ Bolt-On Cutting Edges	General Purpose w/ Teeth and Skid Shoes	General Purpose w/ Bolt-On Cutting Edges
Bucket Capacity	3.1 m ³	3.1 m ³	3.0 m ³	2.8 m ³	2.7 m ³	3.7 m ³
A Height to Top of Cab and Canopy	3436 mm	3436 mm	3436 mm	3436 mm	3436 mm	3436 mm
B Ground Clearance	418 mm	418 mm	418 mm	418 mm	418 mm	418 mm
C Length from Centerline to Front Axle	1600 mm	1600 mm	1600 mm	1600 mm	1600 mm	1600 mm
D Wheelbase	3200 mm	3200 mm	3200 mm	3200 mm	3200 mm	3200 mm
E Dump Clearance	2932 mm	2940 mm	3019 mm	3349 mm	3437 mm	3237 mm
F Height to Hinge Pin, Fully Raised	4075 mm	4075 mm	4075 mm	4501 mm	4501 mm	4501 mm
G Dump Reach	1079 mm	1069 mm	1020 mm	1091 mm	1033 mm	1203 mm
H Maximum Digging Depth	112 mm	112 mm	82 mm	147 mm	117 mm	161 mm
I Overall Length	8105 mm	8205 mm	8187 mm	8482 mm	8566 mm	8666 mm
J Maximum Rollback Angle at Ground Level	43 deg.	43 deg.	43 deg.	42 deg.	42 deg.	42 deg.
K Maximum Rollback Angle with Boom Fully Raised	56 deg.	56 deg.	56 deg.	55 deg.	55 deg.	55 deg.
L Maximum Dump Angle at Maximum Height	44 deg.	44 deg.	44 deg.	45 deg.	45 deg.	45 deg.
M Hood Height	2376 mm	2376 mm	2376 mm	2376 mm	2376 mm	2376 mm
R1 Steering Radius to Outside of Bucket, Carry Position	6444 mm	6492 mm	6492 mm	6637 mm	6682 mm	6691 mm
R2 Steering Radius to Outside of Rear Tire	5777 mm	5777 mm	5777 mm	5777 mm	5777 mm	5777 mm
Bucket Width	2937 mm	2963 mm	2963 mm	2937 mm	2963 mm	2937 mm
Breakout Force	18 772 kg	18 931 kg	20 512 kg	18 127 kg	19 780 kg	15 957 kg
Tipping Load, Straight	13 502 kg	13 468 kg	13 864 kg	11 766 kg	12 011 kg	11 370 kg
Tipping Load, 40-deg. Full Turn	11 684 kg	11 650 kg	12 003 kg	10 117 kg	10 348 kg	9742 kg
Machine Weight	16 783 kg	16 810 kg	16 668 kg	17 098 kg	16 982 kg	17 333 kg

Loader operating information is based on machine with identified linkage and standard equipment, PowerTech engine (EU Stage II), ROPS cab, rear concrete bumper/counterweight, transmission side-frame guards, bottom guards, standard tires, full fuel tank, and 79-kg operator. This information is affected by changes in tires, ballast, and different attachments, and assumes no tire deflection per the standard ISO 14397-1 section 5.

Bucket Selection Guide

