

772 P

6WD Motor Grader



JOHN DEERE





MAKE GRADE AND MOVE AHEAD IN A BIG WAY

For almost six decades, John Deere motor graders have been building a reputation for outstanding control and effortless grading precision. Thanks to the best ideas of customers like you, we've achieved a legacy of industry firsts. Productivity boosters enabled with the Grade Pro option like exclusive automation features, cross slope, return to straight, and lever steering. Plus your choice between dual-joystick or fingertip controls. With a tall mainframe that smoothly shoulders large loads and clears obstacles, the 772 P-Tier's exceptional balance, optimized performance specs, and reliable capability can help you take grading performance to the next level and your operation in a reimagined new direction.

772 P-TIER 6WD MOTOR GRADER

FEATURES

Driven to precision

On six-wheel-drive models precision mode allows the operator to manage a consistent speed via dial switch instead of inching pedal, maximizing productivity in all soil conditions. Six-wheel drive is adjustable on the fly to capably traverse difficult jobsites.

Power that checks and balances

Increased engine horsepower, torque, and blade pull over earlier models produce generous power and lugging ability, to deliver more power to the ground, easily pull through tough spots, or tackle steep hills. John Deere motor graders are designed with optimal weight distribution over each axle, for outstanding balance and grading performance.

Freedom of choice

Our P-Tier Graders let you choose how work gets done. Our Grade Pro option provides fatigue-minimizing electrohydraulic (EH) controls that are armrest mounted. Opt for state-of-the-art dual-joystick or fingertip controls that mimic the conventional control pattern. The best of both worlds is available with a field kit that allows you to easily swap between the two. Our P-Tier models also offer conventional lever-operated controls. And based on customer feedback, all models still have a steering wheel.

Count on cross slope

Standard on Grade Pro-optioned machines, cross slope maintains slopes by automatically adjusting one side of the blade while the operator controls the other. Cross slope can also be operated in "manual mode" as a slope meter. Automated cross slope simplifies holding a consistent slope by reducing operation to a single lever. Both dual-joystick and fingertip controls come equipped with cross slope.



+



**CONFIGURABLE
CONTROL
OPTIONS**

**FACTORY EQUIPPED
WITH GRADE PRO
TECHNOLOGY**

Uptime is everything

All daily service points including fuel refill are grouped on the left side of the machine for convenient ground-level access. On the right, periodic-service points including the engine oil, hydraulic, transmission, differential and fuel filter bank are within easy reach. Cooling package minus stacked coolers plus hinged swing-out fan simplifies core cleanout. Variable-speed hydraulically driven fan runs only as fast or as often as needed, to conserve power and fuel while reducing noise.

Premium productivity

Featuring a fully sealed bearing and pinion that run smoother and quieter, the industry-leading design of the optional premium circle reduces operating costs while delivering 40-percent more torque and 15-percent more speed than a traditional circle. The premium circle eliminates having to compensate for wear in the circle and improves accuracy when using a grade-control system. And greasing intervals of only four zerks every 500 hours make the premium circle essentially maintenance free. Durable dual-input and proven single-input circles are also available.

Picture yourself here

All-around visibility is virtually unobstructed, with a clear view to the heel and toe as well as behind the moldboard. You can also see the area beneath the front axle, for increased awareness of oncoming obstacles. LCD hi-vis monitor provides intuitive, push-button access to vital machine data displayed via simple, easy-to-navigate icons and menus. High-resolution rearview camera with dedicated in-cab monitor comes standard.

Precision Construction

John Deere construction equipment comes with in-base connectivity — free from subscriptions or annual renewals. Analyze critical machine data, track utilization, review diagnostic alerts, and more from the **John Deere Operations Center™**. The Operations Center also enables **John Deere Connected Support™**, which uses data from thousands of connected machines to proactively address issues before they arise. Your dealer can also remotely monitor machine health, diagnose problems, and even update machine software without a trip to the jobsite.*

*Availability varies by region and product. Options not available in every country.



**INTUITIVE
AUTOMATION SUITE**
STREAMLINES MACHINE CONTROL





772 P-TIER 6WD MOTOR GRADER

PUT INTELLIGENCE TO WORK

With **Automation Suite** including industry-exclusive Auto-Pass, Blade Flip, and Auto-Shift PLUS, it's push-button easy to set yourself apart from your competition. Our automation advantages are available from the factory when the motor grader is equipped with electrohydraulic (EH) controls, or they can be added to the machine in the future:

- Available with any control configuration, **Auto-Shift PLUS** allows operators to work without using the inching pedal.
- **Auto-Articulation** lets the operator increase the maneuverability of coordinated steering and articulation while using only the joystick-steering function to steer and operate other necessary functions without manually articulating the machine.
- **Machine-Damage Avoidance** eliminates the risk of blade damage to machine structures during any operation.
- **Auto-Pass** makes grading easy by automatically placing the blade on the ground and activating the grade-control system (when equipped) at the start of the pass, then automatically raising and resetting the blade at the end of it.
- Use **Blade Flip** to automatically mirror the circle to a preset angle.
- Easily prepare the machine for transport with **Machine Presets**. Stow the blade and ripper, turn on the lights including the hazards, and enable Auto-Shift with one push-button press.



While general information, pictures, and descriptions are provided, some illustrations and text may include product options and accessories NOT AVAILABLE in all regions, and in some countries products and accessories may require modifications or additions to ensure compliance with the local regulations of those countries.

Engine		772 P-TIER	
Manufacturer and Model	John Deere PowerTech™ Plus 9.0L	John Deere PowerTech™ 9.0L	
Non-Road Emission Standard	EPA Tier 3/EU Stage IIIA	EPA Tier 2/EU Stage II	
Cylinders	6	6	
Displacement	9.0L (548 cu. in.)	9.0L (548 cu. in.)	
Net Engine Power			
Gear 1	164 kW (220 hp)	164 kW (220 hp)	
Gear 2	172 kW (230 hp)	172 kW (230 hp)	
Gear 3	179 kW (240 hp)	179 kW (240 hp)	
Gear 4	183 kW (245 hp)	183 kW (245 hp)	
Gear 5	187 kW (250 hp)	187 kW (250 hp)	
Gear 6	194 kW (260 hp)	194 kW (260 hp)	
Gear 7	201 kW (270 hp)	201 kW (270 hp)	
Gear 8	194 kW (260 hp)*	194 kW (260 hp)*	
Net Peak Torque	1300 Nm (959 lb.-ft.)	1300 Nm (959 lb.-ft.)	
Net Torque Rise	57%	57%	
Aspiration	Turbocharged, charge-air cooled	Turbocharged, charge-air cooled	
Lubrication	Full-flow spin-on filter and integral cooler	Full-flow spin-on filter and integral cooler	
Air Cleaner With Restriction Indicator	Dual element, dry	Dual element, dry	
<i>*6WD not available.</i>			
Cooling			
Engine Coolant, Extended Life, Rating	-37 deg. C (-34 deg. F)		
Powertrain			
6-Wheel Drive	Automatic dual-path hydrostatic drive; increases tractive effort and front-end control; includes separate left and right systems with variable-displacement pumps, axial-piston wheel motors, and freewheel at transport speeds; operator-selectable 15-position rotary aggressiveness control and inching capability down to 0 mph; precision mode (propelled by front wheels only)		
Effective Gears	1-7 forward and reverse		
Precision Mode			
Effective Gears	1-3 forward only		
Operating Speeds	0.4-8.0 km/h (0.25-5.0 mph)		
Hydrostatic Pumps (2 each)	60 cm ³ (3.7 cu. in.)		
Wheel Motors	60 cm ³ (3.7 cu. in.)		
Final Reduction	38.7:1		
Transmission	Direct-drive John Deere PowerShift Plus™, modulated shift-on-the-go, Event-Based Shifting (EBS), inching pedal; independent transmission reservoir with separate filtration and cooling system with 117-L/min. (31 gpm) gear pump		
Gears			
Forward	8		
Reverse	8		
Maximum Travel Speeds	<i>No tire slip at 2,180 rpm, 14.0-R24 tires</i>		<i>No tire slip at 2,180 rpm, 14.0-R24 tires</i>
Gear 1	4.0 km/h (2.5 mph)	Gear 5	16.4 km/h (10.2 mph)
Gear 2	5.6 km/h (3.5 mph)	Gear 6	23.2 km/h (14.4 mph)
Gear 3	7.7 km/h (4.8 mph)	Gear 7	32.3 km/h (20.1 mph)
Gear 4	10.9 km/h (6.8 mph)	Gear 8	45.5 km/h (28.3 mph)
Front Axle	Heavy-duty welded fabrication		
Oscillation (total)	32 deg.		
Wheel Lean Angle (each direction)	20 deg.		
Differentials	Spiral bevel; hydraulically actuated, clutch type can be applied on-the-go; selectable manual or automatic differential lock		
Steering (all models include steering wheel)	All-hydraulic power-frame articulation for maneuverability and productivity; crab steering reduces side drift, positions tandems on firm ground, and increases side-slope stability; return-to-straight control included in Grade Pro option		
Turning Radius (front steer and articulation)	7.21 m (284 in.) (23 ft. 8 in.)		
Articulation (both right and left)	22 deg.		
Final Drives	Inboard-mounted planetary sealed in cooled, filtered oil		
Brakes	Foot-controlled, hydraulically operated, multiple wet-disc brakes sealed in pressurized, cooled, filtered oil; both independent systems effective on all 4 tandem wheels		
Primary and Secondary Brakes	Hydraulically actuated, inboard of tandem pivot, self-adjusting, sealed in cooled and filtered oil, multi-disc (ISO 3450)		
Parking Brake	Automatically spring applied, hydraulically released, oil cooled, self-adjusting (ISO 3450)		

772 P-TIER MOTOR GRADER SPECIFICATIONS

772

P

While general information, pictures, and descriptions are provided, some illustrations and text may include product options and accessories NOT AVAILABLE in all regions, and in some countries products and accessories may require modifications or additions to ensure compliance with the local regulations of those countries.

Hydraulics		772 P-TIER
Type	Closed-center, pressure-compensated load-sensing (PCLS), variable-displacement piston pump	
Maximum Pump Flow	212 L/min. (56 gpm)	
Maximum System Pressure	18 961 kPa (2,750 psi)	
Pump Displacement	90 cm ³ (5.5 cu. in.)	
Blade Function		
All-hydraulic, industry-standard lever placement of blade-function controls; includes float position; 7 discrete saddle positions		
Blade Range		
Lift Above Ground	490 mm (19.3 in.)	
Blade Side Shift (right or left)	683 mm (26.9 in.)	
Pitch at Ground Line		
Forward	42 deg.	
Back	5 deg.	
Shoulder Reach Outside Wheels (frame straight, right or left)	2083 mm (82.0 in.) (6 ft. 10 in.)	
Bank Cut Angle (right or left)	90 deg.	
Blade Pull		
At Maximum Operating Weight	22 453 kg (49,500 lb.)	
Electrical		
Solid-state load center and sealed-switch module		
Voltage	24 volt	
Number of Batteries	2	
Battery Capacity	1,010 CCA	
Reserve Capacity	190 min.	
Amp-Hour Rating	110 amp-hour	
Alternator Rating		
Base	100 amp	
Optional	130 amp	
Lights	Driving lights; 2 high- and 2 low-beam halogen headlights; front and rear LED turn signals and marker lights; LED brake and hazard warning lights	
Mainframe		
Type	Welded box construction	
Width (minimum)	307 mm (12.1 in.)	
Height (minimum)	307 mm (12.1 in.)	
Thickness		
Side	16 mm (0.63 in.)	
Top and Bottom Plate	23 mm (0.89 in.)	
Modulus		
Minimum Vertical Section	1770 cm ³ (108 cu. in.)	
Average Vertical Section at Saddle	2245 cm ³ (137 cu. in.)	
Draft Frame (drawbar)		
Welded box construction machined for flatness with double ball-and-socket pivot connection		
Circle		
Welded construction, heat-treated, machined for flatness		
	<i>Standard Circle</i>	<i>Premium Circle</i>
Circle Diameter	1524 mm (60 in.)	1524 mm (60 in.)
Rotation	360 deg.	360 deg.
Surface	Quick-change bronze or nylon wear inserts	Sealed and lubricated roller element slewing bearing
Pinion/Ring-Gear Connection	Adjustable backlash and open for serviceability	No adjustment; fully sealed and lubricated
Drive	Hydraulic motor and worm gear with positive lock	Hydraulic motor and worm gear with positive lock
Slip Clutch	Option	Standard
Circle Side Shift (right and left)	787 mm (31 in.)	787 mm (31 in.)
Moldboard		
High-strength, pre-stressed for higher strength, wear-resistant, high-carbon steel and reversible end bits; blade side-shift wear system includes quick-change replaceable wear inserts and quick-adjust jackscrew system		
Base Length	3.66 m (144 in.) (12 ft. 0 in.)	
Height (measured along arc, including cutting edge)	610 mm (24 in.)	
Thickness	22 mm (0.88 in.)	

772 P-TIER

While general information, pictures, and descriptions are provided, some illustrations and text may include product options and accessories NOT AVAILABLE in all regions, and in some countries products and accessories may require modifications or additions to ensure compliance with the local regulations of those countries.

Cutting Edge		772 P-TIER		
Dura-Max™ through-hardened steel edge				
Thickness	16 mm (0.62 in.)			
Width	152 mm (6 in.)			
Scarifiers				
<i>Mid-mount</i>				
Type	Radial linkage, with NeverGrease™ pin joints; V-type manual 3-pitch positions and hydraulic float			
Width of Cut	1.19 m (46.7 in.) (3 ft. 11 in.)			
Number of Shanks/Teeth	11			
Lift Above Ground	335 mm (13.2 in.)			
Maximum Depth	325 mm (12.8 in.)			
Shank				
Spacing	117 mm (4.6 in.)			
Size	25 x 76 mm (1 x 3 in.)			
Front Lift Group (Balderson-style)				
Parallel linkage, mechanical pins, and hydraulic float				
Lift				
Above Ground (top of tube)	1864 mm (73.4 in.)			
Range	988 mm (38.9 in.)			
Rear Ripper/Scarifier				
Parallel linkage, with NeverGrease pin joints, hydraulic float, and integrated hitch				
		<i>Ripper</i>		<i>Scarifier</i>
Width of Cut	2.21 m (87.2 in.) (7 ft. 3 in.)		2.18 m (86 in.) (7 ft. 2 in.)	
Number of Shanks/Teeth	3 (maximum capacity 5)		None standard (maximum capacity 9)	
Lift Above Ground	602 mm (23.7 in.)		810 mm (31.9 in.)	
Maximum Depth	426 mm (16.8 in.)		323 mm (12.7 in.)	
Force				
Penetration	9863 kg (21,745 lb.)		—	
Pry-Out	14 368 kg (31,676 lb.)		—	
Shank Size	61.5 x 133 mm (2.42 x 5.25 in.)		25 x 76 mm (1 x 3 in.)	
Operator Station				
Low-profile cab with ROPS (ISO 3471-2008) and FOPS (ISO 3449-2005)				
Tires/Wheels				
	<i>14R24 on 254-mm (10 in.) Rim</i>	<i>17.5R25 on 356-mm (14 in.) Rim</i>	<i>550/65R25 on 432-mm (17 in.) Rim</i>	
Wheel Tread on Ground	2.08 m (82.0 in.)	2.16 m (85.0 in.)	2.21 m (87.0 in.)	
Overall Width	2.49 m (98.0 in.)	2.64 m (104.0 in.)	2.82 m (111.0 in.)	
Ground Clearance (front axle)	587 mm (23.1 in.)	587 mm (23.1 in.)	612 mm (24.1 in.)	
Serviceability				
Refill Capacities				
Fuel Tank	416.5 L (110 gal.)			
Cooling System	48.5 L (12.8 gal.)			
Engine Oil With Filter	28.0 L (7.4 gal.)			
Transmission Fluid	28.4 L (7.5 gal.)			
Differential Housing	38.0 L (10 gal.)			
Tandem Housings (each)	74.0 L (19.5 gal.)			
Circle Gearbox	5.7 L (1.5 gal.)			
Hydraulic Reservoir	53.0 L (14 gal.)			
Operating Weights				
With Full Fuel Tank, 3.66-m x 610-mm x 22-mm (12 ft. x 24 in. x 0.88 in.) Moldboard				
With 152-mm x 16-mm (6 in. x 5/8 in.) Cutting Edges, 14R24 L2 Tires, and 79-kg (175 lb.) Operator				
Front	4944 kg (10,900 lb.)			
Rear	11 948 kg (26,340 lb.)			
Total	16 892 kg (37,240 lb.)			
Typical Operating Weight With Front Push Block, Rear Ripper/Scarifier, and Other Equipment				
Front	6343 kg (13,985 lb.)			
Rear	13 547 kg (29,865 lb.)			
Total	19 890 kg (43,850 lb.)			
Maximum Operating Weight	24 948 kg (55,000 lb.)			

While general information, pictures, and descriptions are provided, some illustrations and text may include product options and accessories NOT AVAILABLE in all regions, and in some countries products and accessories may require modifications or additions to ensure compliance with the local regulations of those countries.

772 P-TIER

Option Weights	772 P-TIER
Moldboards With Through-Hardened Dura-Max Cutting Edge	
3.66 m x 610 mm x 22 mm (12 ft. x 24 in. x 7/8 in.)	0 kg (0 lb.)
With 152-mm x 16-mm (6 in. x 5/8 in.) Cutting Edge and 16-mm (5/8 in.) Hardware	
3.66 m x 610 mm x 22 mm (12 ft. x 24 in. x 7/8 in.)	45 kg (99 lb.)
With 203-mm x 19-mm (8 in. x 3/4 in.) Cutting Edge and 16-mm (5/8 in.) Hardware	
3.96 m x 686 mm x 25 mm (13 ft. x 27 in. x 1 in.)	180 kg (396 lb.)
With 203-mm x 19-mm (8 in. x 3/4 in.) Cutting Edge and 16-mm (5/8 in.) Hardware	
4.27 m x 610 mm x 22 mm (14 ft. x 24 in. x 7/8 in.)	105 kg (231 lb.)
With 152-mm x 16-mm (6 in. x 5/8 in.) Cutting Edge and 16-mm (5/8 in.) Hardware	
4.27 m x 610 mm x 22 mm (14 ft. x 24 in. x 7/8 in.)	157.4 kg (347 lb.)
With 203-mm x 19-mm (8 in. x 3/4 in.) Cutting Edge and 16-mm (5/8 in.) Hardware	
4.27 m x 686 mm x 25 mm (14 ft. x 27 in. x 1 in.)	251 kg (554 lb.)
With 203-mm x 19-mm (8 in. x 3/4 in.) Cutting Edge and 16-mm (5/8 in.) Hardware	
4.27 m x 686 mm x 25 mm (14 ft. x 27 in. x 1 in.)	261 kg (575 lb.)
With 203-mm x 19-mm (8 in. x 3/4 in.) Cutting Edge and 19-mm (3/4 in.) Hardware	
Overlay End Bits, Reversible (one pair)	
For 152-mm (6 in.) Cutting Edge	19.5 kg (43 lb.)
For 203-mm (8 in.) Cutting Edge	23 kg (51 lb.)
Heavy-Duty Dual-Input Circle-Drive Gearbox	14 kg (31 lb.)
Circle-Drive Slip Clutch	9 kg (20 lb.)
Circle	
Standard	0 kg (0 lb.)
Premium	289 kg (638 lb.)
Moldboard Impact-Absorption System	43 kg (95 lb.)
Ripper/Scarifier, Rear Mounted With Hitch and Ripper Shanks (3)	1139 kg (2,510 lb.)

Machine Dimensions	
A Height to Top of Cab	3.18 m (10 ft. 5 in.)
A' Height to Top of Full-Height Cab	3.40 m (11 ft. 2 in.)
B Height to Top of Exhaust	3.10 m (10 ft. 2 in.)
C Height to Top of Blade-Lift Cylinders	3.05 m (10 ft. 0 in.)
D Tandem Axle Spacing	1.54 m (5 ft. 1 in.)
E Blade Base	2.57 m (8 ft. 5 in.)

Option Weights (continued)	772 P-TIER
Scarifier Shanks With Teeth (9 for rear ripper/scarifier)	68 kg (150 lb.)
Ripper Shanks and Teeth (2)	63 kg (139 lb.)
Rear Counterweight With Integral Rear Hitch	727 kg (1,603 lb.)
Rear Hitch	54.4 kg (120 lb.)
Push Block, Front	1338 kg (2,950 lb.)
Scarifier, Mid-Mount With Teeth (11)	1481 kg (3,265 lb.)
Tires	
14.00-24, 12 PR G2	-220.4 kg (-486 lb.)
17.5-25, 12 PR G2/L2	-106 kg (-234 lb.)
14.00-R24, Radial, G2/L2 General Purpose	0 kg (0 lb.)
14.00-R24, Radial, G2/L2 Snow	40.8 kg (90 lb.)
17.5-R25, Radial, L2 General Purpose	51.7 kg (114 lb.)
17.5-R25, Radial, G2/L2 Snow	95.3 kg (210 lb.)
17.5-R25, Radial, G3/L3 General Purpose	141.5 kg (312 lb.)
550/65R25 XLD70 G3/L3 Radial, General Purpose	495.3 kg (1,092 lb.)
Multi-Piece Rims	
254 mm x 610 mm (10 in. x 24 in.)	0 kg (0 lb.)
356 mm x 635 mm (14 in. x 25 in.)	85.3 kg (188 lb.)
432 mm x 635 mm (17 in. x 25 in.)	131.6 kg (290 lb.)
Low Cab With Opening Front and Side Windows	14.5 kg (32 lb.)
Premium Air-Suspension, Heated Seat With Adjustable Arm- and Headrests	13 kg (28 lb.)
Coolant Heater	4 kg (9 lb.)
Quick Service	11 kg (24 lb.)
Secondary Steering	26 kg (58 lb.)
Beacon Bracket	8 kg (18 lb.)
Lighting Packages	
10 Halogen Lights	4.5 kg (10 lb.)
18 Halogen Lights	8 kg (18 lb.)
Auxiliary Hydraulic Control Valve Section and Controls	7 kg (15 lb.)
Hydraulics for Front-Mounted Equipment	9 kg (19 lb.)

Machine Dimensions (continued)	
F Wheelbase	6.16 m (20 ft. 3 in.)
G Overall Length	8.89 m (29 ft. 2 in.)
H Overall Length With Scarifier	9.69 m (31 ft. 9 in.)
I Overall Length With Push Block and Ripper	9.99 m (32 ft. 9 in.)
II Overall Length With Scarifier and Ripper	10.59 m (34 ft. 9 in.)

For Overall Width see Tires/Wheels on page 8.

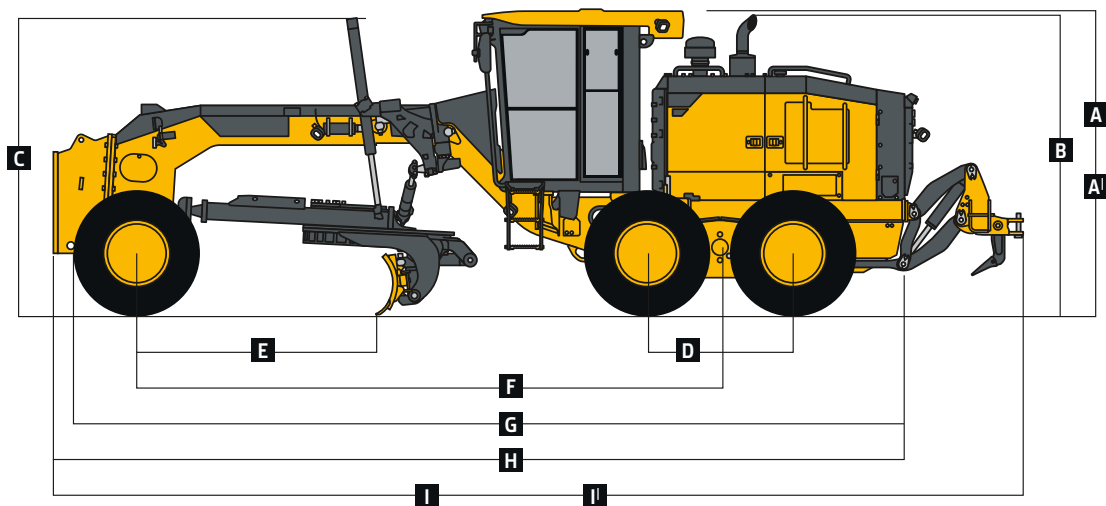

Additional equipment

Key: ● Standard ▲ Optional or special

See your John Deere dealer for further information.

772 P Operator's Station

- Low-profile ROPS/FOPS cab with HVAC (ROPS ISO 3471 / FOPS SAE 3449 Level II)
- ▲ Low-profile ROPS/FOPS cab utilizing laminated glass with fixed lower front and side opening windows
- ▲ Opening side windows (standard with Grade Pro)
- Keyless start with multiple security modes
- Fabric air-suspension seat with armrests and headrest
- ▲ Premium heated, leather/fabric, high-wide-back, air-suspension seat with armrests (standard with Grade Pro)
- Sealed-switch module with function indicators
- Electric rear-window defroster
- Upper front windshield washers with intermittent wipers
- Upper rear windshield washers with intermittent wipers
- ▲ Powered cab precleaner
- ▲ Decelerator pedal
- ▲ Flip-down right-hand cab beacon bracket

772 P Operator's Station (continued)

- Front window sun visor
 - ▲ Retractable rear sunshade
 - Rearview mirrors, exterior (2) (SAE J985)
 - ▲ Heated exterior mirrors (2) (SAE J985)
 - ▲ High-resolution rear camera with dedicated in-cab monitor (in some markets)
 - ▲ High-resolution front/rear-camera combination with dedicated in-cab monitor
 - Retractable seat belt, 76 mm (3 in.) (SAE 386)
 - ▲ AM/FM radio with auxiliary and Weather Band (WB)
 - Push-button-activated cruise control
- ### Electrical
- 100-amp alternator
 - ▲ 130-amp alternator
 - Batteries (2), 1,010 CCA with 190-min. reserve capacity
 - ▲ Batteries (2), 1,400 CCA with 440-min. reserve capacity
 - Left-hand engine compartment service-check light
 - Transporting lights (4 halogen)

772 P Electrical (continued)

- Grading lights (10 halogen)
 - ▲ Deluxe grading lights (18 halogen)
 - Multifunction/multi-language diagnostic LCD color monitor
 - Reverse warning alarm (SAE J994)
 - LED brake and turn lights
- ### Moldboard
- Patented pre-stressed, high strength, wear resistant:**
- 3.66 m x 610 mm x 22 mm (12 ft. x 24 in. x 7/8 in.)
 - ▲ 3.96 m x 686 mm x 25 mm (13 ft. x 27 in. x 1 in.)
 - ▲ 4.27 m x 610 mm x 22 mm (14 ft. x 24 in. x 7/8 in.)
 - ▲ 4.27 m x 686 mm x 25 mm (14 ft. x 27 in. x 1 in.)
 - Quick-change and jackscrew-adjustable moldboard side-shift extreme-duty wear inserts
 - ▲ Reversible overlay endbits
- ### Overall Vehicle
- JDLink™ wireless communication system (available in specific countries; see your dealer for details)

While general information, pictures, and descriptions are provided, some illustrations and text may include product options and accessories NOT AVAILABLE in all regions, and in some countries products and accessories may require modifications or additions to ensure compliance with the local regulations of those countries.

Net engine power is with standard equipment including air cleaner, exhaust system, alternator, and cooling fan at test conditions specified per ISO 9249. No derating is required up to 3050-m (10,000 ft.) altitude. Specifications and design subject to change without notice. Wherever applicable, specifications are in accordance with SAE standards. Except where otherwise noted, these specifications are based on a unit with standard equipment; 14.0 x 610-mm (24 in.) 12 PR G2, Bias tires; and 3.66-m x 610-mm x 22-mm (12 ft. x 24 in. x 7/8 in.) high-strength, wear-resistant moldboards with 16-mm x 152-mm (0.63 in. x 6 in.) Dura-Max® through-hardened-steel cutting edges. Weights include lubricants, coolants, full fuel tank, and 79-kg (175 lb.) operator.

Additional equipment *(continued)*

Key: ● Standard ▲ Optional or special

See your John Deere dealer for further information.

772 P Overall Vehicle *(continued)*

- Ground-level fuel filling
- Fluid-sampling ports for engine oil and coolant, hydraulic oil, and axle and transmission fluids
- Vandal-protection locking for: Cab doors / Top tank radiator-access door / Engine coolant surge tank / Hydraulic reservoir cap / Battery-disconnect switch / Ground-level electrical master disconnect switch / Fuel-tank door and cap / Toolbox
- Environmental drains with hoses for engine, transmission, hydraulic, differential fluids, and engine coolant
- Hydraulically driven cool-on-demand reversing fan
- Banked easy-access vertical spin-on filters for hydraulic, transmission, and axle fluids
- Engine rotary ejector precleaner
- Automatic differential lock
- Engine-stall prevention and auto shutdown
- Single-input circle drive with slip clutch
- ▲ Single-input circle drive

772 P Overall Vehicle *(continued)*

- ▲ Heavy-duty dual-input circle drive with slip clutch
- ▲ Premium circle
- ▲ Auto-Shift transmission
- ▲ Auto-Shift PLUS transmission
- ▲ Blade-impact-absorption system
- ▲ Quick-service bank for transmission, hydraulic, engine oil, and engine coolant fluid changes
- ▲ Wheel chocks

Automation *(optional with Grade Pro)*

- ▲ Automation Suite
- ▲ Auto-Articulation
- ▲ Auto-Pass
- ▲ Blade Flip
- ▲ Machine Presets
- ▲ Machine-Damage Avoidance

Front Attachments

- Front push block
- ▲ Mid-mount scarifier with float position, 11 shanks
- ▲ Front-mounted dozer blade, 2464 mm (97 in.)
- ▲ Front-mounted dozer blade, 2667 mm (105 in.)

772 P Rear Attachments

- Full bottom guard with access panel and side guards for rear vehicle protection
- ▲ Rear-mounted ripper/scarifier combination with rear hitch and pin, 3 ripper shanks
- ▲ Rear counterweight with rear hitch and pin
- ▲ Scarifier shanks (9) with teeth for rear ripper scarifier
- ▲ Extra ripper shanks (2) with teeth for rear ripper/scarifier

Grade Pro Option

- Low-profile Grade Pro cab utilizing laminated glass with fixed lower front and side opening windows
- Premium heated, leather/fabric, high-wide-back, air-suspension seat with armrests
- ▲ Dual-joystick controls
- ▲ Fingertip armrest-mounted controls including lever steering
- Steering wheel
- Cross slope
- Return to straight

While general information, pictures, and descriptions are provided, some illustrations and text may include product options and accessories NOT AVAILABLE in all regions, and in some countries products and accessories may require modifications or additions to ensure compliance with the local regulations of those countries.

Net engine power is with standard equipment including air cleaner, exhaust system, alternator, and cooling fan at test conditions specified per ISO 9249.

No derating is required up to 3050-m (10,000 ft.) altitude. Specifications and design subject to change without notice. Wherever applicable, specifications are in accordance with SAE standards. Except where otherwise noted, these specifications are based on a unit with standard equipment; 14.0 x 610-mm (24 in.) 12 PR G2, Bias tires; and 3.66-m x 610-mm x 22-mm (12 ft. x 24 in. x 7/8 in.) high-strength, wear-resistant moldboard with 16-mm x 152-mm (0.63 in. x 6 in.) Dura-Max® through-hardened-steel cutting edges. Weights include lubricants, coolants, full fuel tank, and 79-kg (175 lb.) operator.



MG772PAB (24-01)



JOHN DEERE